

**FUND
FOR
PUBLIC
SCHOOLS**

2009 Annual Report

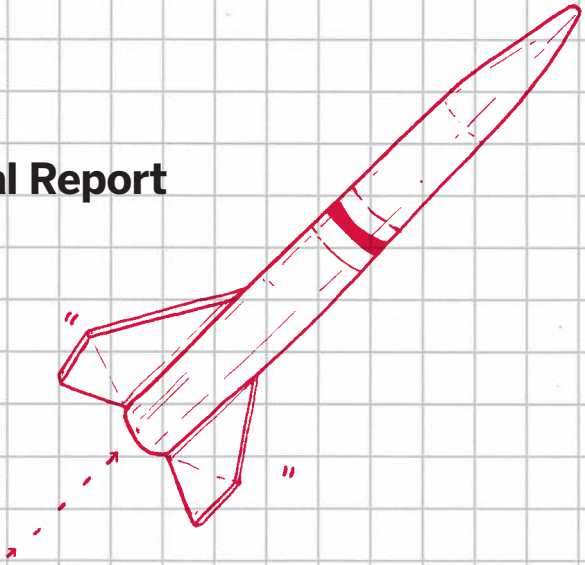

Pioneering Advances in Education

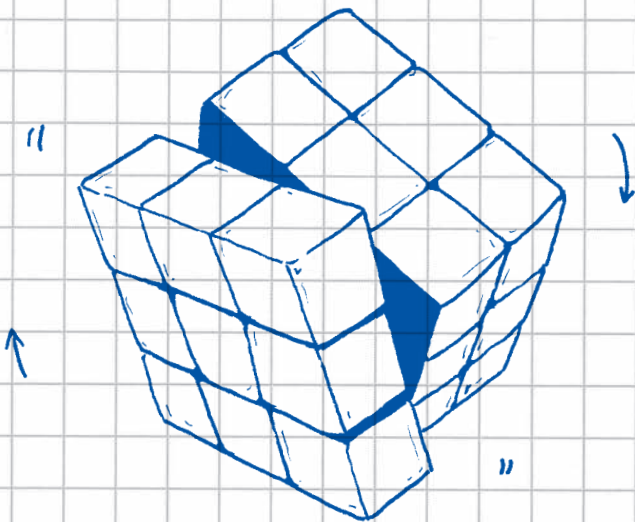



This is not traditional education philanthropy. The Fund for Public Schools uses private investment for true transformational change to drive innovation in our schools.

Joel I. Klein, Schools Chancellor

The world around us is constantly evolving – technologically, economically, politically, and in every other conceivable way. **We can't assume that instructional techniques developed decades ago are going to adequately prepare our students for the challenges of the future.** Now is the time to begin piloting new methods of instruction to ensure that we have a workforce capable of meeting the demands of industry, and able to compete on the world's stage. In 2009, The Fund for Public Schools proudly supported some of the most advanced, innovative new concepts in education taking place in New York City.

At the same time, we can't forget about the tried-and-true fundamentals of learning. Students need their families to be involved in their education, and we must give parents the tools and information they need to actively support their children. Access to a wide range of rich literature is vital to the learning experience, and a comprehensive arts education supports and enhances learning in all other subject matters – from English Language Arts to Environmental Science.

We've come a long way, but we can't stop working to improve public education in New York City. **Pioneering advances in education means paving the way for a brighter, better future for our city and our nation.** Thank you for joining me in this challenging and endlessly rewarding endeavor.

Caroline Kennedy, Vice-Chair

The Fund for Public Schools is the nonprofit organization dedicated to improving New York City's public schools by attracting private investment in school reform and encouraging greater involvement by all New Yorkers in the education of our children.

PIONEERING ADVANCES IN EDUCATION

EDUCATION. CLASSROOM. INSTRUCTION. These words conjure up well-known images of the schools of our youth. **But education as we know it is changing shape here in New York City.**

The typical classroom structure was developed without the benefit of what we know today about children's learning capacities and abilities. **No two students process information in the same way, so one cookie cutter approach to teaching and learning won't be effective for all students.** We need to find ways to give every student the educational experience that is best suited to his or her individual learning style.

We must also ensure that the content our students are learning is meaningful in the global marketplace. **The curriculum we use in the classroom today was created long before technology threw open the door to industries that require new and different skill sets.** We must give our students an education that will be relevant when they graduate.

We are pleased to be involved in some of the most exciting work to pioneer advances in education. In the following pages you will learn about some of these initiatives supported by The Fund for Public Schools in fiscal year 2009.

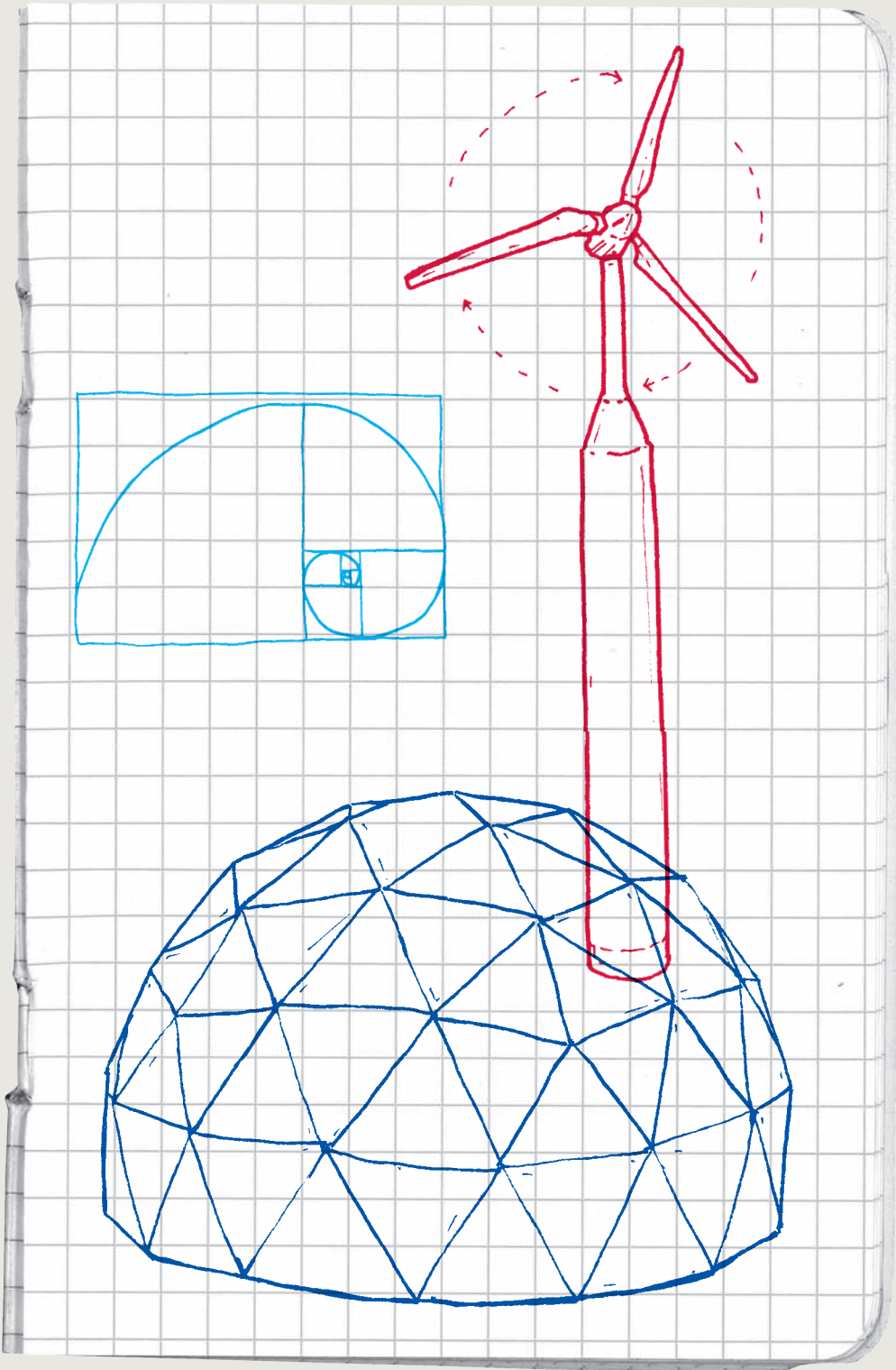

Creating the Classroom of the Future

IN 2009, The Fund supported the launch of School of One, a pilot program that re-envisioned classroom instruction for middle school Mathematics, giving each student individualized learning experiences tailored to his or her specific needs and learning styles. Instead of one teacher standing at the head of the class, **this unique model breaks up the classroom, allowing students to learn in smaller groups, get one-on-one tutoring, study independently, and work with virtual tutors.** Each student receives a daily schedule that is custom-created to support his or her specific academic needs, challenging more advanced students to move ahead once they've mastered a skill set, and allowing students who are struggling to keep working until they really understand a lesson.

This level of individualized instruction would not be possible without a sophisticated learning algorithm that synthesizes data, including students' learning preferences, instructional content, daily assessments, and available classroom space. Every day, teachers work with timely data about their students' progress and adapt their instructional lessons accordingly. This use of technology gives teachers more time to focus on what they do best: delivering high-quality instruction.

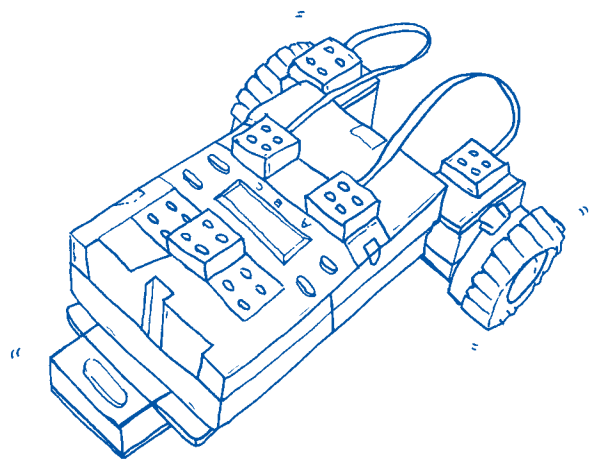

The results were extraordinary. Our teachers were inspired, our students engaged, our parents intrigued, and our school community couldn't wait to bring School of One back this year.

Principal Phyllis Tam, M.S. 131



Preparing Students for the Workforce

TODAY'S STUDENTS need the higher-level knowledge and skills required to compete in the global marketplace. To better serve our city's students, we continued our work in 2009 to redesign Career and Technical Education programs, **leveraging private dollars to help launch new demonstration sites that will give students access to meaningful career paths in rapidly growing industries.** One of the four sites launched in fall 2009 is City Polytechnic High School of Engineering, Architecture, and Technology (City Poly). Integrating academic rigor with opportunities to learn career-specific skills, City Poly offers students an accelerated high-school-to-college pathway. Hard-working students can complete their high school requirements in just three years and can move directly into an associate's degree program at CUNY's New York City College of Technology.

We can't do this alone. Our Career and Technical Education demonstration sites rely heavily on partnerships with industry and higher education leaders **to ensure that curriculum and learning experiences are relevant and aligned with the realities of the workforce.** Representatives of Cisco and Parsons Brinckerhoff are prominent members of City Poly's Advisory Board and have provided funding for special programs and guest speakers in City Poly classrooms and at student recruitment events.

Improving New York City's public schools is critical to the future of our city.

Mortimer B. Zuckerman, Vice-Chair, The Fund for Public Schools



Revolutionizing Instructional Delivery

TODAY'S LEADING EMPLOYERS seek job applicants with higher-order skills such as analytical thinking, oral and written communications, and team-building. **Our schools need to better prepare our students with the skills they will need to be able to compete in the global marketplace.** The NYC iSchool, launched with support from The Fund in September 2008, is meeting this challenge with the use of state-of-the-art technology to engage students in an interdisciplinary, project-based, college preparatory curriculum.

Students learn to be creative, analytical thinkers while using technology to collaborate within teams, complete tasks, and solve complex, real-world problems. Using video conferencing technology, the iSchool frequently invites experts from various fields and locations to be virtual guest lecturers in students' classes, enabling them to study with subject-matter experts anywhere in the world.

Private support has been a critical factor in the success of the NYC iSchool. **A high daily attendance rate (95%) and exemplary performance on Regents exams indicate a motivated, engaged student body.** The school's success has not gone unnoticed: the school received more than 1,500 applications for the 100 seats in the 2009-10 freshman class.

By engaging in technology-integrated learning experiences grounded in real world situations, NYC iSchool students will graduate with a well-rounded liberal arts education, excellent technology skills, and a strong sense of global citizenship.

Providing Richer, More Relevant Learning

IN THE NEW INFORMATION ECONOMY, those who know how to access information, to understand it, to apply it, and to articulate it both through the spoken and written word will succeed, while those who do not have these skills will find few employment opportunities. More than any other time in history, **comprehending words on the page — and understanding the context in which words are used — are the most critical skills we can give our children.** Children living in poverty are not developing these skills at the level necessary to compete in the 21st century economy. Effective early literacy instruction is key to leveling the playing field.

The Core Knowledge Early Literacy curriculum, developed by Dr. E.D. Hirsch, author of *The Knowledge Deficit*, aims to address the achievement gap by arming all children early on with literacy skills and the general knowledge that strengthens comprehension skills in later grades.

In 2008, The Fund for Public Schools partnered with the New York City Department of Education to launch a pilot of the Core Knowledge curriculum. We are happy to report that during fiscal year 2009 we saw promising results. **The kindergarten students in Core Knowledge pilot schools showed six times the gain from fall to spring on literacy assessments** when compared to the students of similar demographic profile at comparison schools. Additionally, schools that participated in the first year of the pilot all chose to continue using the curriculum with their own funds, indicating that teachers are finding it to be such a strong resource that schools are willing to invest in it going forward.

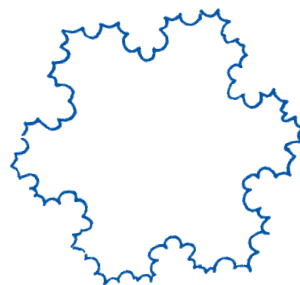

KEEPING THE BASICS STRONG

IF YOU ASK A ROOM full of people to list the most important aspects of a well-rounded education, they are likely to provide many of the same answers: parent involvement, rich literature, and the arts. While exploring new areas of instructional innovation is critical to the future of our city and our nation, **we must also rigorously maintain these fundamental elements that make for a solid, robust education.** To this end, in 2009 The Fund continued to support parent engagement initiatives, public school libraries, and arts education programs as we have for years.

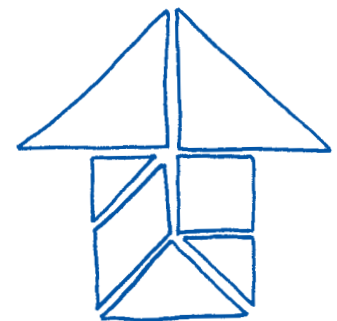
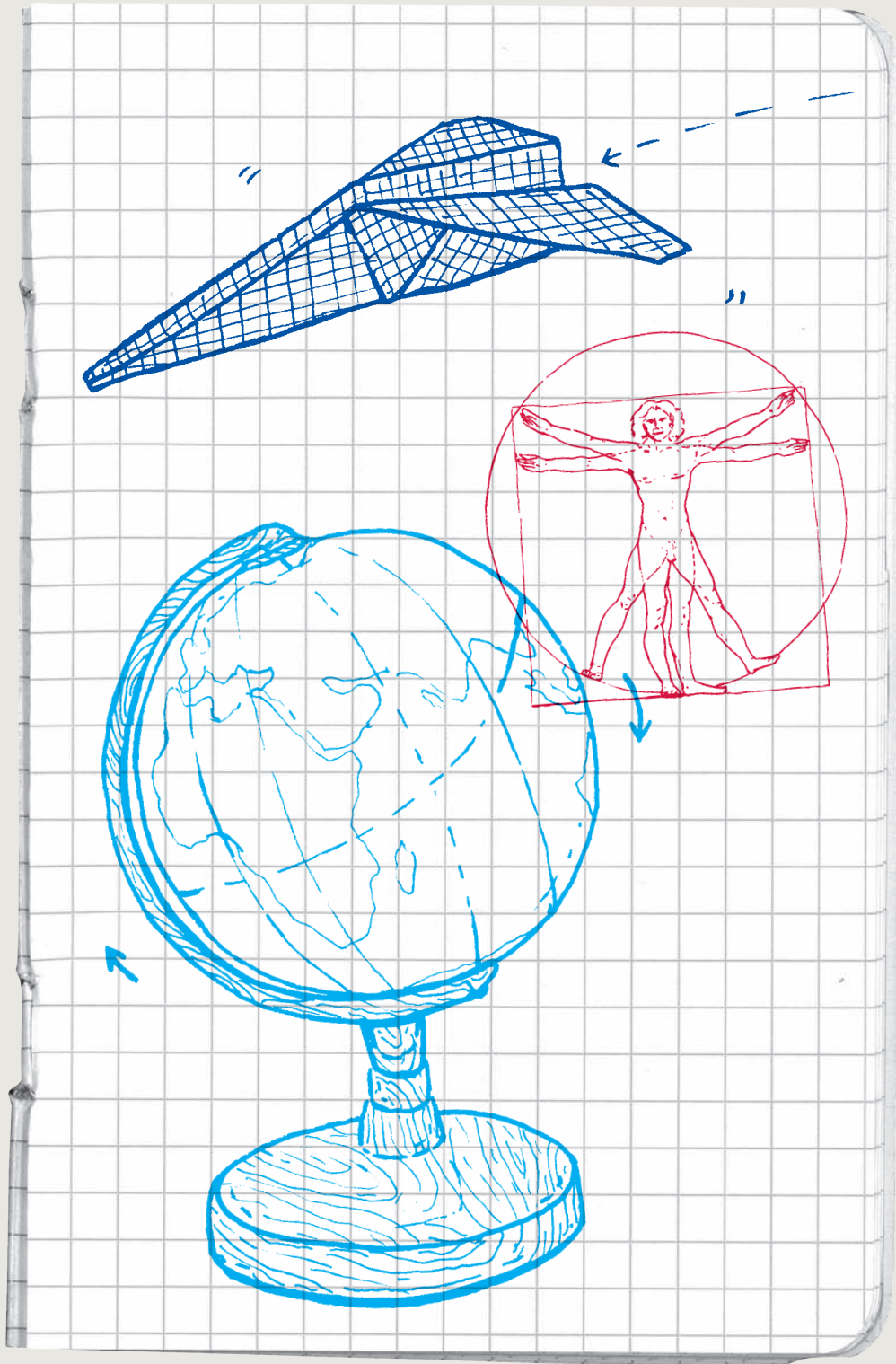

Expanding Access to Quality Arts Education

FISCAL YEAR 2009 ushered in The Fund's largest single gift for arts education to date. Fashion icon Giorgio Armani gave back to New York City with a gift of one million dollars to support **innovative arts programs in the south Bronx**. His grant made possible the expansion of the DreamYard Art Center and established a pilot arts education program in six elementary schools.

In addition to Armani's grant, The Fund continued to raise support for arts education initiatives, like the creation of the Moving Image Blueprint, a guide for the many schools who have requested support in establishing a film curriculum. **Our Arts SPACE (Supporting Performing Arts and Creative Education) grants created new and improved performing arts spaces in ten schools**. And we once again supported the Summer Arts Institute, a free, four-week summer arts program.

Revitalizing Public School Libraries

MOST OF US can recall with great nostalgia our favorite childhood books; the stories fueled our imaginations and introduced us to a world beyond our homes. For many needy students, school is the place they are most likely to come into contact with books, but their **school libraries are too often bereft of the resources they need**. In 2009, The Fund expanded our work with school libraries, including:

- Awarding Library REACH (Revitalizing Education for Adolescents and Children) grants to 32 schools across the city to transform their libraries.
- Facilitating a partnership with Macy's to create New Yorkers Read nonfiction book clubs in over 100 public middle schools with the goal of **connecting students to real-life reasons to read**.
- Launching Family Reading Nights, which are supported by Target and invite parents into the school library to learn strategies for reading to their children.

The Art Center has helped DreamYard provide opportunities to hundreds of young people and their families and to dozens of public schools and their teachers. This investment could not have come at a better time for the Bronx.

Jason Duchin, Co-Executive Director, DreamYard

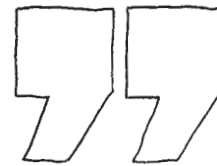

Empowering Parents

FAMILIES ARE AN INTEGRAL ASPECT of their students' academic success. But navigating a complex web of information sources has long been a challenge for parents. In 2009, The Fund supported two initiatives to streamline this process: Parent Link and P311.

Parent Link is a **web-based resource that gives parents up-to-date information on their child's progress** and suggestions for addressing their child's academic issues. Parent Link is part of the NYC Department of Education's recently launched Achievement Reporting and Information System (ARIS), which provides educators with a consolidated view of critical student information.

P311 is a new **hotline for parents and guardians seeking information about their children's education**. This new resource is an extension of the city's 311 Customer Service Center, a 24-7 hotline that provides access to government information and services. Families can now simply dial 311 to reach an expert trained in responding to education issues, greatly simplifying the time and know-how it takes parents to get their questions answered.

Never before in New York City have parents had easy access to this much information about their children's academic progress. Ultimately, this information will **deepen the collaboration between parents and educators and give families the tools they need to hold their schools accountable** for student achievement results.

Message from the CEO

A TIME OF ECONOMIC CRISIS gives us an opportunity to reflect on the future of our country, much of which rests on how well we are educating our children. It is now clear that the achievement gap between white and Asian students and their black and Latino peers has had a demonstrably negative impact on our economy. A recent study showed that if we closed the racial achievement gap, our nation's GDP could increase between \$300 billion and \$500 billion, and if we closed the international achievement gap, our GDP could increase by trillions. (McKinsey & Company, 2009)

We simply cannot afford to look the other way while other nations' children make advancements in education that we are not able to provide to our own.

Instead, we must challenge the status quo in our schools and move them to higher standards of excellence for all of New York City's 1.1 million students.

Philanthropy can play a significant role in supporting the innovations that will give our children the rigorous, college and career-preparatory education they require to compete in today's global economy. I am happy to report that The Fund for Public Schools was able to meet our fundraising goals for 2009 despite the economic downturn. **The funding we raised provided a critical lever to enable the New York City Department of Education to launch and test initiatives that push the boundaries of traditional classroom education.**

We are proud that The Fund for Public Schools is able to be a part of the movement in New York City to develop new solutions to the long-standing problems in public education. The students of today are our future; they alone will power the engine of economic growth in years to come.

Stephanie Dua, CEO

FINANCIAL REPORT

Fiscal Year July 1, 2008 to June 30, 2009

In fiscal year 2009, The Fund for Public Schools raised \$14.85 million to support initiatives of the New York City Department of Education.* Spending for program services was approximately \$37.3 million, up from \$26.2 million in the previous fiscal year. Expenses supported arts, libraries, scholarships, and the continuation of system-wide reform efforts.

Funds Raised for the NYC Department of Education

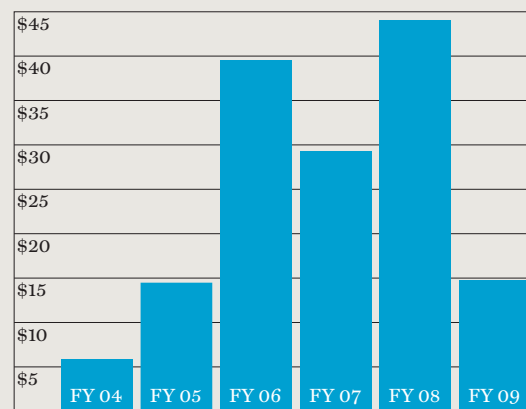

*This number includes \$.05 million raised to support the NYC Leadership Academy. From 2003 through 2009, The Fund sought and accepted contributions on behalf of the Leadership Academy, a separate nonprofit entity. These contributions were received by The Fund and transferred to the Leadership Academy. In keeping with accounting principles, the contributions received for the Leadership Academy are not included in the financial statements of The Fund.

(2, 3, 5, 7, 11...)

Statement of Income and Expense For Fiscal Years 2009 and 2008

	2009 July 1 – June 30	2008 July 1 – June 30
Support And Revenue		
Contributions and Grants*	\$14,805,079	\$43,400,389
Fee Income	0	5,250
Donated Services	741,497	756,030
Realized & Unrealized Gains on Investments	79,643 (164,032)	
Interest Income	707,518	903,601
Total Support And Revenue	\$16,333,737	\$44,901,238
Expenses		
Grant Expense:		
Grants to NYC Department of Education	\$36,610,821	
Awareness Initiative	2,721,175	3,417,313
	37,331,996	26,257,414
Supporting Expense:		
Management & General	1,323,939	918,729
Fundraising	498,619	590,510
	1,822,558	1,509,239
Total Expenses	\$39,154,554	\$27,766,653
Increase/(Decrease) In Net Assets Discontinued Program	\$(22,820,817) (2,472,877)	\$17,134,585
Net Assets - Beginning of Year	\$62,859,541	45,724,956
Net Assets – End Of Year	\$37,565,847	\$62,859,541

Copies of the complete audited financial statements from which this information was excerpted are available upon request.

Donors

\$1,000,000 and above

Cisco Systems	The Carroll and Milton Petrie Foundation
Bill & Melinda Gates Foundation	Robertson Foundation
GE Foundation	Robin Hood Foundation
Giorgio Armani Corporation	Tortora Sillcox Family Foundation

\$500,000 - \$999,999

The Broad Foundation	Michael & Susan Dell Foundation
The Carson Family Charitable Trust	Goldman Sachs & Co.

\$100,000 - \$499,999

American Express Company	Goldie Anna Charitable Trust
Arnhold Foundation, Inc.	Hospital League /1199 SEIU Fund
Bank of America	Macy's East, Inc.
The Bank of New York Mellon	National Football Fdtn & College Hall of Fame
Best Buy	New York Life Foundation
Booth Ferris Foundation	The Shubert Foundation, Inc.
The Broadway League	Verizon Foundation
Department of City Planning	The Wachovia Foundation, Inc.
Doshi Diagnostic Imaging Services	

\$50,000 - \$99,999

Hugh L. Carey Battery Park City Authority	MetLife Foundation
Centerbridge Foundation	NFL Ventures, LP
HSBC Bank in the Community (USA) Inc.	Target Corporation
Kinray, Inc.	Vornado Office Management
Marc Jacobs International	Working In Support of Education

\$25,000 - \$49,999

Association for a Better New York	National Academy Foundation
Barnes & Noble Booksellers	New York Community Trust
BNP Paribas	Nike, Inc.
Deloitte & Touche LLP	Rock and Roll Hall of Fame Foundation
Freeman Harrison Family Foundation	Select Equity Group, Inc.
Beth Kaufman	Staples Foundation for Learning
The Litwin Foundation	Theory, LLC
Lord & Taylor	Trendfund
Moody's Foundation	David & Sybil Yurman Humanitarian & Arts Foundation
Morgan Stanley	

\$5,000 - \$24,999

Advanced Technology Center	Governor's Committee on Scholastic Achievement
AEA Investors LLC/Aetos Capital	Richard and Peggy Greenfield Foundation
Anchin, Block & Anchin, LLP	Home Box Office, Inc.
Anonymous	Interpublic Group
Irwyn Applebaum	J.Crew
The Atlantic Philanthropies	The JVK Foundation
Atlantic Yards Development Co., LLC	The Kaplen Foundation
Bath & Body Works, LLC	Kenneth Cole New York
Benzak Foundation	Kern High School District
Big City Volleyball League	Abe & Francis Lastfogel Foundation
BJ's Wholesale Club	G. Seth Leyman
Blackman High School	Marcus Pointe Baptist Church
BlackRock Financial Management, Inc	Mattel Children's Foundation
Bloomberg L.P.	Mercer County Community College
CBRE/CB Richard Ellis	Murray G. & Beatrice H. Sherman Charitable Trust
Christian Dior, Inc.	National City Bank
Cisco Learning Institute	National Trade and Banking High School
Citigroup Foundation	New York Yankees
Davis Polk & Wardwell LLP	Nohra Haime Gallery
Dedalus Foundation, Inc.	The Opportunity Charter School
Del Shaw Moonves Tanaka Finkelstein & Lezcano	The Peter Jay Sharp Foundation
Dial A Mattress Operating Corporation	Polo Ralph Lauren Foundation
John DiMurro	Prada USA
Disney Worldwide Services, Inc.	The Prudential Foundation
Thomas L. Eisenberg	Red Apple Group, Inc.
Elephant Rock Foundation	Rochester City School District
The Estee Lauder Companies Inc.	Romano Family Trust
Ezra Jack Keats Foundation	Charles Morgan Royce
Financial Security Assurance, Inc.	Saks Fifth Avenue
Financial Women's Association of New York	SC Virtual Enterprise Network
Fordham Leadership Academy Business & Technical High School	Stamford Public Education Foundation
Forest City Ratner Companies	Stop & Stor Charitable Fund
Fred E. Kassner Foundation	Time Inc.
Burton M. Freeman	Twentieth Century Fox
Friends of the High School for Leadership & Public Service	Vincent Mulford Foundation
Constance R. Giustizia	Adam J. Winkel
Greer E. Goodman	Worldwide Pants Incorporated
	Young Professionals Mentoring Program

Shop for Public Schools Retailers

Acorn - A Brooklyn Toy Shop
Alex&Sam
American Girl Place
Annie's Blue Ribbon General Store
AOC Fine Wines
Audio Town
AJX Armani Exchange
Barnes & Noble Booksellers
Best Buy NoHo
Blue Spoon Coffee Company
Borders, Inc.
Bx. Fashion
Call Me Wireless
Christian Dior
Citibabes
Cohen's Gentle Dental
The Compleat Strategist, Inc.
Conway
crewcuts
Cynthia Rowley
Daffy's
David Yurman
Diane von Furstenberg
Dinosaur Hill
DKNY
Elicia Brown, Beauty Consultant with Mary Kay
Elie Tahari
Emigrant Savings Bank
The Estee Lauder Companies Inc.
Fendi
Fishes Eddy, Inc.
Fordham Road BID
Fordham Road Jewelry Exchange
Gem Pawnbrokers
Harlem's Heaven Hat Boutique
The Intrepid Sea, Air & Space Museum
Ivanka Trump
J. Crew
J. Crew Collection
J. Crew Men's Shop
J. Rembrandt, Author
Jeunesse 'Spas For Life'

Jimmy Choo
Kenneth Cole New York
Kidding Around
Kids World of The Bronx
Little Marc Jacobs
Macy's
Madewell
Manolo Blahnik
Marc by Marc Jacobs Accessories
Marc by Marc Jacobs Men
Marc by Marc Jacobs Women
Marc Jacobs Collection Accessories
Marc Jacobs Men's and Women's Collection
Michael Kors
Modell's Sporting Goods
The MTV Store
My Tiny Closet
N Boutique
One Girl Cookies
Original Products
Plain Mary
Planet Earth Communications
Rosie J Designs
Saks Fifth Avenue
Sam Ash Music Stores
Samantha Thavasa NYC
Soutine
Space Kiddets
The St. Regis New York
Staples
Starbright Floral Design
Super Runners Shop, Inc.
Theory
Top Concourse Electronics & Computers
Tory Burch
Tribeca Treats
Tupperware
Unique Boutique NYC
Urban Eyes Optical
Vera Wang
Wireless Warehouse
Zero + Maria Cornejo

About Us

Board of Directors

Joel I. Klein, Chair
Caroline Kennedy, Vice-Chair
Mortimer B. Zuckerman, Vice-Chair
Richard L. Menschel, Treasurer
Jeanette Sarkisian Wagner, Secretary
Charles H. Googe, Jr.
Agnes Gund
Wendi Murdoch
Leonard Riggio
Elizabeth Rohatyn

Officers

Stephanie Dua, Chief Executive Officer
Tara Paone, Chief Financial Officer

To Donate

Donations to support public education in New York City can be made to The Fund for Public Schools. Donations can be made through The Fund's website at www.fundforpublicschools.org or by mailing a check to:

The Fund for Public Schools
52 Chambers Street, Room 305
New York, NY 10007

Donors can specify an area of focus for their donation.

For more information, please contact The Fund at info@fundforpublicschools.org or 212-374-2874.

Also, please follow our work on Facebook, MySpace, and Twitter.

Design by Pentagram
Illustration by Maayan Pearl
This report was paid for with private funds.



All of us have a responsibility, as Americans...to offer every single child in this country an education that will make them competitive in our knowledge economy. That is our obligation as a nation.

President Barack Obama

**FUND
FOR
PUBLIC
SCHOOLS**

www.fundforpublicschools.org

52 Chambers Street
Room 305
New York, NY 10007
212-374-2874